



NECA/FOA 301-2016

Standard for

Installing and Testing Fiber Optics

AN AMERICAN NATIONAL STANDARD



Published by
National Electrical Contractors Association



Jointly developed with
The Fiber Optic Association

NECA/FOA 301-2016

Standard for

Installing and Testing Fiber Optics

**An American
National Standard**



Published by
National Electrical
Contractors Association



Jointly developed with
The Fiber Optic Association



Revision History	
NECA/FOA 301-2004 originally published	12/2004
NECA/FOA 301-2009 revised	12/2009
NECA/FOA 301-2016 revised	10/2016

NOTICE OF COPYRIGHT

This document is copyrighted by NECA

ISBN: 978-1-944148-17-1

©2016. Reproduction of these documents either in hard copy or soft (including posting on the web) is prohibited without copyright permission. For copyright permission to reproduce portions of this document, please contact NECA Standards & Safety at (301) 215-4549, or send a fax to (301) 215-4500.

OR

National Electrical Contractors Association
3 Bethesda Metro Center, Suite 1100
Bethesda, Maryland 20814
(301) 657-3110

Table of Contents

- 1. Scope 1**
 - 1.1 Products and Applications Included 1
 - 1.2 Regulatory and Other Requirements 1
 - 1.3 Fiber Optic Topologies..... 1
 - 2.1 Definitions 3
 - 2.2 Abbreviations And Acronyms..... 6

- 3. Safety and Cautions for Fiber Optic Installation..... 7**
 - 3.1 Fiber Optic Installation Safety 7
 - 3.2 Cleanliness 8

- 4. Installation Requirements 9**
 - 4.1 General Guidelines 9
 - 4.2 Support Structures 9
 - 4.3 Removal of Abandoned Cables 9
 - 4.4 Fire Stopping 10
 - 4.5 Grounding and Bonding 10

- 5. Fiber Optic Cables..... 11**
 - 5.1 Cable Types..... 11
 - 5.2 Flammability — Cable Ratings and Markings 12
 - 5.3 Fiber Optic Cable Color Codes 12
 - 5.4 Installing Fiber Optic Cable..... 13
 - 5.5 Cable Plant Hardware 15
 - 5.6 Use of Cable Ties..... 15

- 6. Fiber Optic Termination..... 16**
 - 6.1 General..... 16
 - 6.2 Fiber Optic Connectors 16
 - 6.3 Fiber Optic Splices 18

- 7. Testing the Installed Fiber Optic Cable Plant..... 19**
 - 7.1 General..... 19
 - 7.2 Continuity Testing..... 19
 - 7.3 Insertion Loss 19
 - 7.4 OTDR Testing..... 19

- 8. Administration, Management, and Documentation 21**
 - 8.1 General..... 21

Annex A: Calculating the Loss Budget for a Fiber Optic Cable Plant..... 22
A.1 Information Necessary to Calculate Loss Budget.....22
A.3 Calculate the fiber loss:23
A.4 Calculate the connector loss:23
A.5 Calculate the splice loss:.....24
A.6 To calculate the total cable loss, add the losses calculated above:24
A.7 Interpreting the result:24

Annex B: Field Test Requirements 25
B.1 General.....25
B.2 Insertion Loss Of Fiber Optic Cables.....25
B.3 OTDR Testing.....27

Annex C: Reference Standards..... 29

(This foreword is not a part of the standard)

Foreword

National Electrical Installation Standards™ are designed to improve communication among specifiers, purchasers, and suppliers of electrical construction services. They define a minimum baseline of quality and workmanship for installing electrical products and systems. *NEIS®* are intended to be referenced in contract documents for electrical construction projects. The following language is recommended:

Fiber optic cables shall be installed in accordance with NECA/FOA 301, *Standard for Installing and Testing Fiber Optics*.

Use of *NEIS®* is voluntary, and neither the National Electrical Contractors Association nor the Fiber Optic Association assumes any obligation or liability to users of this publication. Existence of a standard shall not preclude any member or nonmember of NECA or FOA from specifying or using alternate construction methods permitted by applicable regulations.

The installation and maintenance practices recommended by this publication are intended to comply with the edition of the National Electrical Code (NEC) in effect at the time of publication. Because they are quality standards, *NEIS®* may in some instances go beyond the minimum requirements of the NEC. It is the responsibility of users of this standard to comply with state and local electrical codes when installing electrical products and systems.

Suggestions for revisions and improvements to this standard are welcome. They should be addressed to:

NECA Codes and Standards
3 Bethesda Metro Center, Suite 1100
Bethesda, MD 20814
(301) 215-4521 telephone
(301) 215-4500 fax
neis@necanet.org

To purchase *National Electrical Installation Standards®*, contact the NECA Order Desk at (301) 215-4504 telephone, (301) 215-4500 fax, or orderdesk@necanet.org. *NEIS®* can also be purchased in .pdf download format from www.neca-neis.org/catalog.

Copyright© 2016, National Electrical Contractors Association. All rights reserved. Unauthorized reproduction prohibited.

National Electrical Installation Standards and *NEIS* are trademarks of the National Electrical Contractors Association. National Electrical Code and NEC are registered trademarks of the National Fire Protection Association, Quincy, Massachusetts.

<This page intentionally left blank>

1. Scope

This standard describes procedures for installing and testing cabling networks that use fiber optic cables and related components to carry signals for communications, security, control and similar purposes. It defines a minimum level of quality for fiber optic cable installations.

1.1 Products and Applications Included

This standard covers fiber optic cabling installed indoors (premises installations) with the addition of outside plant (OSP) applications involved in campus installations where the fiber optic cabling extends between buildings. Although the standard covers premises installations, many of the provisions included here are also applicable to outside plant installations.

1.2 Regulatory and Other Requirements

This publication is intended to comply with ANSI/NFPA 70, the National Electrical Code (NEC). It is the responsibility of users of this publication to comply with state and local electrical codes, OSHA occupational safety regulations as well as follow manufacturer's installation instructions when installing electrical products and systems.

The information in this publication is also intended to comply with the following:

- ANSI/IEEE C2, National Electrical Safety Code
- ANSI/TIA 568, Commercial Building Telecommunications Cabling Standard
- ANSI/TIA 569, Commercial Building Standard for Telecommunications Wiring Pathways and Spaces
- ANSI/TIA 606, Administration Standard for Commercial Telecommunications Infrastructure
- ANSI/TIA 607, Commercial Building Grounding and Bonding Requirements for Telecommunications
- ANSI/TIA-758 Customer Owned Outside-Plant Telecommunications Infrastructure Standard
- IEEE 1100, IEEE Recommended Practice for Powering and Grounding Electronic Equipment
- NECA/BICSI 568 Standard for Installing Commercial Building Telecommunication Cabling (ANSI)

Since standards are continually being revised, one should refer to the latest version of any relevant standard.

Only qualified persons familiar with installation and testing of fiber optic cabling should perform the work described in this publication. The term "qualified person" is defined in Article 100 of the NEC.

Other National Electrical Installation Standards provide additional guidance for installing particular types of electrical products and systems. A complete list of NEIS is provided in Annex C.

The Fiber Optic Association, Inc., the professional society of fiber optics, maintains an extensive technical reference web site on fiber optics. This website covers topics related to fiber optic technology, components, installation, testing, troubleshooting and standards in depth. Visit <http://foaguide.org> for more complete information.

1.3 Fiber Optic Topologies

Fiber optic cabling can be used for computer networks (LANs), closed circuit TV (video), voice links (telephone, intercom, audio), building

management, security or fire alarm systems, or any other communications link.

In premises applications, fiber optic cables can be used as the backbone cabling in a standard structured cabling network, connecting network hardware in the computer room/main cross connect to local network hardware in a telecom closet. Fiber may also be used for horizontal cabling with network equipment or media converters in or at the connected devices.

In an optimized fiber optic network, cables go directly to the work area with only passive connections in the links. This architecture is called “centralized fiber optic cabling.” Backbone cables typically contain larger numbers of fibers than horizontal fiber optic cables, and may contain singlemode fibers as well as multimode fibers.

Premises fiber optic networks may also use the same network architecture used for fiber to the

home (FTTH) called a passive optical network (PON). These networks use an optical splitter to share electronics for as many as 32 users. These networks are called OLANs (optical LANs) or POLs (passive optical LANs.) Each user is connected by one singlemode fiber that transmits signals bi-directionally. The layout of an OLAN is identical to centralized fiber architecture.

Outside plant (OSP) fiber optic cable installations are typically point-to-point links with terminations inside buildings housing the communications equipment and intermediate connections in sealed closures. OSP cables may be installed by direct burial underground, pulled in underground ducts or conduit and mounted on poles in aerial installations. Fiber optic cable is also placed underwater across rivers or lakes.

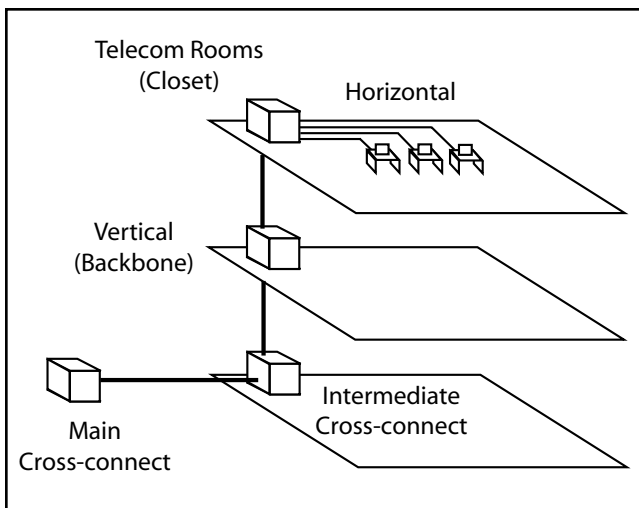

Figure 1. Structured cabling architecture per TIA-568.

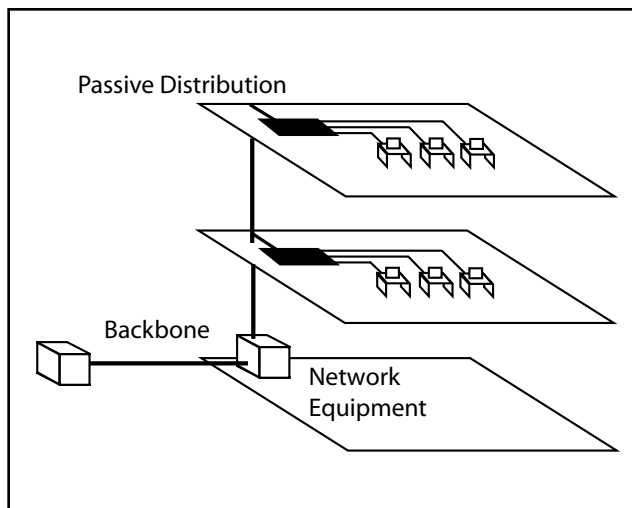

Figure 2. Cabling for centralized fiber architecture and OLANs.

2. Definitions, Abbreviations, and Acronyms

2.1 Definitions

Attenuation Coefficient The *optical* loss of fiber per unit length, expressed in dB/km.

Backscattering The scattering of light in a fiber back toward the source, used to make OTDR (Optical Time Domain Reflectometer) measurements.

Bandwidth The range of signal frequencies or bit rates within which a fiber optic component, link or network will operate.

Bending or Microbending Loss Loss in fiber caused by stress on the fiber bent around a restrictive radius. Most fiber optic cables are specified for a radius of 10 times the cable diameter unloaded or 20 times the cable diameter under pulling tension.

Bend-Insensitive Multimode Fiber Fiber designed and manufactured to withstand a smaller bend radius than nonbend-intensive fiber, enabling lower losses or damage.

Buffer A protective plastic coating applied directly to the optical fiber. Also called *primary coating*.

Cable One or more fibers enclosed in protective coverings and strength members.

Cable Plant The combination of fiber optic cable sections, connectors and splices forming the optical path between two terminal devices.

Cladding The lower refractive index optical coating over the core of the fiber that “traps” light into the core.

Cleave To precisely break an optical fiber to prepare it for splicing or termination.

Composite Cable A cable containing both optical fibers and electrical conductors.

Connector A device that provides a demountable connection between two fibers or a fiber and an active device.

Continuity Tester A visible light source used to confirm continuity and trace fibers.

Core The center of the optical fiber through which light is transmitted.

Decibel (dB) A unit of measurement of optical power that indicates relative power on a logarithmic scale. $dB = 10 \log (\text{power ratio})$.

Dispersion The spreading of a pulse in an optical waveguide that affects bandwidth. May be caused by modal or chromatic effects.

End Finish The quality of the end surface of a fiber prepared for splicing or terminated in a connector, tested by visual inspection in a microscope.

Ferrule A precision tube, which holds a fiber in alignment for interconnection or termination. A ferrule may be part of a connector or mechanical splice.

Fiber Optics Light transmission through flexible transmissive fibers for communications or lighting.

Fiber To The Home (FTTH) Connecting subscribers to the network for phone, Internet or over fiber optics.

Fresnel Reflection Light reflected from the cleaved or polished end of a fiber caused by the difference of refractive indices of air and glass. Also called *Reflectance*, *Back Reflection* or *Optical Return Loss*.

Fusion Splice A permanent joint between two fibers created by heating the fibers and fusing the joint.

Fusion Splicer A precision instrument that joins two fibers together by melting and fusing them.

Graded Index Fiber A type of multimode fiber, which uses a graded profile of refractive index in the core material to correct for modal dispersion.

Hybrid Cable An optical cable containing both singlemode and multimode fibers.

Index Matching Fluid or Gel A fluid or gel with a refractive index similar to the fiber used to match the materials at the ends of two fibers to reduce loss and back reflection.

Insertion Loss The loss caused by the insertion of a component such as a splice or connector in an optical fiber. Also refers to the loss of a cable or cable plant when tested with an optical loss test set.

Jacket The protective outer layer of the cable.

Lambda- λ Greek letter used as a symbol for wavelength.

Launch Cable A high quality fiber optic reference jumper cable used for loss testing, attached to a source and calibrated for output power.

Link, Fiber Optic A combination of transmitter, receiver and fiber optic cable capable of transmitting data.

Loss Budget The estimated amount of power lost in the link.

Loss Margin The additional amount of loss that can be tolerated in a link. The difference between the maximum loss the networking equipment is designed for and the actual loss of the link.

Mechanical Splice A joint between two fibers made with a mechanical alignment device that usually contains index matching gel or adhesive.

Microscope, Fiber Optic Inspection A microscope used to inspect the end surface of a connector for flaws or contamination or the end of a fiber for cleave quality.

Multimode Fiber A fiber with core diameter much larger than the wavelength of light transmitted. It allows many modes (rays) of light to propagate.

Optical Fiber An optical waveguide comprised of a light carrying core, surrounding cladding which traps light in the core and the primary coating.

Optical LAN (OLAN) LAN architecture based on FTTH systems.

Optical Loss The amount of optical power lost as light is transmitted through fiber, splices, couplers, etc.

Optical Loss Test Set (OLTS) Tester comprised of fiber optic power meter and test source used to test the loss of components or cable plants. It is also referred to as LSPM for light source and power meter.

Optical Power The amount of radiant energy per unit time, expressed in linear units or watts or on a logarithmic scale in dB (where $\text{dB} = 10 \log (\text{power}/1 \text{ mW})$, $0 \text{ dBm} = 1 \text{ mw}$).

Optical Time Domain Reflect-o-meter (OTDR)

An instrument that uses back scattered light to find faults in optical fiber and to infer loss for troubleshooting.

Overfilled Launch A condition for launching light into the fiber where the incoming light has a spot size and NA larger than acceptance cone of the fiber, thereby filling all modes in the fiber.

Passive Optical LAN (POL) A LAN based on FTTH passive optical network (PON) systems.

Pigtail A short length of fiber attached to a fiber optic component such as a connector, laser or coupler. Pigtails with connectors can be spliced onto cables as an alternative to direct termination.

Power Budget For network equipment, the difference (in dB) between the transmitted optical power (in dBm) and the receiver sensitivity (in dBm), used to determine the amount of cable plant loss that can be tolerated by the equipment.

Power Meter, Fiber Optic An instrument that measures optical power emanating from the end of a fiber.

Receive Cable A high quality fiber optic reference jumper cable, attached to a power meter used for loss testing.

Reference Test Cable A short single fiber jumper cable with connectors on both ends used for testing. The fiber and connectors must match the cables to be tested.

Singlemode Fiber A fiber with a small core, only a few times the wavelength of light transmitted, that only allows one mode of light to propagate.

Splice A joint or permanent connection between two fibers. See *Fusion Splice* and *Mechanical Splice*.

Step Index Fiber A multimode fiber where the core is composed of a material with the same index of refraction.

Termination Preparation of the end of a fiber to allow non-permanent joining to another fiber or an active device, sometimes called connectorization.

Test Source A laser diode or LED used to inject an optical signal into fiber for testing loss of the fiber or other components.

Visual Fiber Tracer A device that couples low power visible light from a lamp or LED to allow tracing fibers and testing continuity.

Visual Fault Locator A device that couples high power visible light from a laser into the fiber to allow finding breaks, stress loss, tracing and testing continuity.

Wavelength A measure of the color of light, usually expressed in nanometers (nm) or microns (μm).

Wavelength Division Multiplexing (WDM)

Transmitting signals of different wavelengths of light through a fiber simultaneously.

Working Margin The difference (in dB) between the power budget and the loss budget (i.e. the excess power margin).

2.2 Abbreviations And Acronyms

dBm optical power in decibels referenced to 1 milliwatt

OLTS optical loss test set

OTDR optical time domain reflectometer

3. Safety and Cautions for Fiber Optic Installation

3.1 Fiber Optic Installation Safety

3.1.1 General

Safety in fiber optic installation involves many of the same issues as installing any other cable. This includes safety climbing ladders or poles, working with the equipment and processes used in outside plant installations which involve underground and aerial cables and working in areas with hazards typical of construction sites.

Safety in fiber optic installations specifically includes avoiding exposure to light radiation carried in the fiber; disposal of fiber scraps produced in cable handling and termination; and safe handling of hazardous chemicals used in termination, splicing or cleaning according to job and manufacturers' specifications and company or client site-specific standards.

While fiber optic cables generally are all dielectric and carry no electrical power, it may be necessary to work in areas that already have installed electrical power cables and hardware. Care should be taken to avoid these cables or have the power disconnected for the duration of the installation.

The following are examples of safety precautions that should be followed during fiber optic cable installations. This is not a comprehensive list of OSHA regulations governing fiber optic installations.

3.1.2 Eye Protection

- a) Always wear safety glasses with side shields. Always ensure that safety eyewear complies with relevant requirements including OSHA.
- b) After handling fiber, wash hands thoroughly before touching eyes or contact lenses.

- c) Never look directly into the end of any optical fiber unless you are certain that no light is present in the fiber. The light used for signal transmission in fiber optics is generally invisible to the human eye but may operate at power levels that can be harmful to the eye. Inspection microscopes can concentrate the light in the fiber and increase the danger. Use an optical power meter to verify that no light is present in the fiber. Some mobile phone cameras are sensitive in the infrared and may be used to detect light in optical fibers.
- d) When using an optical tracer or continuity checker, look at the fiber from an angle at least 300 mm (12 in.) away from the eye to determine if the visible light is present.

3.1.3 Protection from Fiber Scraps

- a) Small scraps of bare fiber resulting from the termination and splicing process must be disposed of in a container designed for the purpose and marked according to local regulations, as it may be considered hazardous waste.
- b) Do not drop fiber scraps on the floor where they will stick in carpets or shoes and be carried elsewhere. Place them in a marked container or stick them to double-sided adhesive tape on the work surface.
- c) Thoroughly clean the work area when finished. Do not use compressed air to clean off the work area. Sweep all scraps into a disposal container.
- d) Do not eat, drink or smoke near the working area. Fiber particles can be harmful if ingested.
- e) Wash hands well after working with fibers.
- f) Carefully inspect clothing for fiber scraps when

finished working with fiber.

3.1.4 Other Safety Issues

- a) Work only in well-ventilated areas. Confined spaces, such as equipment vaults, manholes can contain toxic or explosive gases or insufficient air to sustain life.
- b) Materials and chemicals used in installation processes may be hazardous. Request Safety Data Sheets (SDS) on all chemicals used.
- c) Fusion splicers create an electric arc. Ensure that no flammable vapors and/or liquids are present. Do not use in confined spaces as defined by OSHA.

3.2 Cleanliness

The small size of optical fibers makes them very sensitive to dust and dirt. Maintain the highest standards of cleanliness when working with fiber to optimize its performance.

3.2.1 Work Rules For Cleanliness

- a) Try to work in clean areas.
- b) Always keep protective dust caps on connectors, mating adapters, patch panels, or test and network equipment.
- c) Do not touch the ends of the connectors.
- d) Only use special cleaning tools made for cleaning optical fiber connectors or use lint-free wipes and pure reagent grade isopropyl alcohol to clean connectors. Other solvents can attack adhesives or leave a residue. Cotton swabs or pads may leave threads behind and are not recommended.
- e) Use dry-cleaning swabs or a source of clean air to blow dust out of mating adapters or equipment inputs/outputs. Clean squeeze bulbs are preferred. Compressed air often contains oils that can contaminate the parts. "Canned air" can be used to blow dust but be aware that many types include a propellant that can contaminate equipment. If

used, spray away from the area to be cleaned for a few seconds before directing it to the area to ensure no liquid propellant is in the spray.

- f) Test equipment fiber inputs/outputs and test cables should be cleaned periodically.

4. Installation Requirements

4.1 General Guidelines

4.1.1 Receiving Fiber Optic Cabling and Equipment on Site

- a) Fiber optic equipment and components are subject to damage by improper handling and must be handled according to the procedures specified for the components by manufacturers' or other relevant documents.
- b) When initially received on the job site, carefully inspect all fiber optic components for damage and test for continuity or loss if damage is suspected.
- c) Ensure that all components and parts have been received, match quantities ordered (e.g. fiber optic cable contains the number and type of fiber ordered and is the length ordered), and that any discrepancies or damaged goods are noted and replaced as required.
- d) Store all equipment and cabling in a clean and dry location, protected from harsh environments and extremes of cold and heat.

4.1.2 Handling Fiber Optic Cables

- a) Handle reels of fiber optic cable with care. All reels, regardless of size or length, must have both ends of the cable available for the testing. A fiber tracer or visual fault locator and bare fiber adapters can be used for continuity testing. Cables suspected of having been damaged in handling may require OTDR testing of a sampling of fibers to verify the condition of the cable.
- b) Move small, lightweight spools of fiber optic cable by hand. Move larger reels with appropriate lifting equipment or using two or more installers skilled in the moving operation.

- c) Move large reels with a matched set of slings or chokers, attached to an appropriately sized piece of pipe inserted into the hole in the center of the reel. Do not attach slings and chokers around the spooled area of the reel. Move cable reels carefully to avoid damage to the cable.

4.2 Support Structures

- a) Install support structures for fiber optic cable installations before the installation of the fiber optic cable itself. These structures should follow all relevant building codes and standards and the guidelines in standards such as TIA-569 and NECA/BICSI-568. Outside plant structures should be installed in conformance with all applicable building codes and standards.
- b) Allow for future growth in the quantity and size of cables when determining the size of the pathway bend radius requirements.
- c) Do not install a fiber optic cable in a conduit or duct that already contains cabling, regardless of the cable type. Existing or new empty ductwork can be modified to accept several different installations by the placement of innerduct within it.

4.3 Removal of Abandoned Cables

Unless directed by the owner or other agency that unused cables are reserved for future use, remove abandoned optical fiber cable (cable that is not terminated at equipment other than a connector and not identified for future use with a tag) as required by the National Electrical Code.

4.4 Fire Stopping

4.4.1 General

- a) All telecommunications fire stopping shall comply with applicable codes and standards, including TIA-569 Annex A and NECA/BICSI-568.
- b) All penetrations shall be protected by approved firestops. Fire stopping compounds and devices shall be used whenever a fire separation has been breached by an installation.
- c) In most geographical locales the breaching of a fire separation will require physical monitoring until it has been repaired.
- d) Check with the “Authority Having Jurisdiction” for specific requirements on the project before commencing work.

4.5 Grounding and Bonding

4.5.1 General

- a) Ground systems shall be designed as specified by the NEC and other applicable codes and standards (IEEE 1100, ANSI/TIA-607, NECA/BICSI 568).
- b) Although most fiber optic cables are not conductive, any metallic hardware used in fiber optic cabling systems (such as wall-mounted termination boxes, racks, and patch panels) must be grounded.
- c) Conductive cables such as metallic-armored cable or composite cables with conductors and fibers require grounding and bonding for applicable conductors according to electrical codes, IEEE C2, IEEE 1100, TIA-607 and TIA-758 standards, manufacturers’ specifications and company or client site-specific standards.

5. Fiber Optic Cables

5.1 Cable Types

Fiber optic cables are available in many types and styles depending on the environment in which they are intended to be installed. Indoor cables must be rated for flame resistance and outside plants must be rated for environmental exposure. The number of fibers in the cable and the type of fiber(s) should be marked on the jacket of the cable.

5.1.1 Cables by Fiber Types

Fiber optic cables may contain multimode optical fibers, singlemode fibers or a combination of the two, in which case it is referred to as a “hybrid” cable. Multimode fibers can be 62.5/125 micron (OM1) fiber, 50/125 (OM2) fiber or 50/125 laser-optimized (OM3 and OM4) fiber. The type or types of fibers included in the cable shall be identified by markings on the jacket and premises cables should have a jacket color per TIA-598. (See Section 5.3.1.)

Fibers with different core diameters are not compatible. Connecting 62.5/125 fiber to 50/125 fiber can lead to excess loss at joints of 1-4 dB. Connecting multimode fiber to singlemode fiber may lead to losses of nearly 20 dB. Cable color codes for identification are covered in Section 5.3.1. Connector types should be chosen to ensure that facilities including more than one type of fiber are properly connected.

The type of fiber optic cable is required to be positively identified and, if hybrid, the type of each fiber, since multimode and singlemode fiber are also terminated in a different manner. *See Section 6 for more information on terminations.*

Many fibers are designed to be “bend insensitive” to allow being installed around tight bends or packed more densely into smaller cables without causing stress loss in the fiber. Some bend-insensitive fibers are not

considered compatible with regular fibers and joining these different types of fibers may cause higher loss joints. Bend insensitive fibers should be identified on the cable jacket and other labeling. For compatibility between bend intensive fiber and non-bend intensive fiber, refer to the manufacturer’s requirements.

5.1.2 Fiber Optic Cables by Construction Type

a) Tight Buffered Cables

Tight-buffered fiber optic cable contains fiber with a soft 900 micron diameter coating that protects the fiber and is color-coded for identification. Tight-buffered fibers are cabled with strength members (usually aramid fibers) in simplex or zip cord cables for use as patch cords.

Multiple tight buffered fibers may be cabled with aramid fiber strength members and a central stiffener in a cable type called a distribution cable, often used for premises backbones, horizontal runs or general building cabling.

Several simplex cables can be bundled in a single cable called a breakout cable. Simplex, zipcord and breakout cables may be directly terminated for connection to a patch panel or network equipment as the cable provides adequate protection for the fibers.

Fibers in distribution cables are terminated directly, but the lack of protection for the fibers requires they be placed inside patch panels or wall-mounted boxes.

b) Loose Tube Cable

Loose tube (also called loose buffer) fiber optic cable consists of one or more protective tubes, each containing one or more fibers with only a 250 micron primary coating over the fiber. Loose tube cable is primarily used for outside plant installations where low attenuation and high cable pulling strength are required.

Many fibers can be incorporated into the same tube, providing a small size, high fiber-density construction. The tubes are usually filled with a gel or dry water-blocking compound that prevents water from entering the cable. The fibers in loose tube cables are protected from the outside environment and can be installed with higher pulling tensions than tight-buffered cables.

Fiber in loose tube cables may be spliced directly and placed in appropriate protective enclosures. Fibers in loose tube cables which have only the 250 micron primary coating should be sleeved with a break out kit for protection before termination and placed in patch panels or wall-mounted boxes for protection.

c) Ribbon Cable

Ribbon cable has fibers in flat groups called ribbons that may contain 12, 24 or 36 fibers. Ribbon cable is chosen when many fibers are needed and the cable must be as small as possible. Ribbons of fibers can be spliced to other ribbons at one time with special fusion splicers or mechanical splices.

5.2 Flammability — Cable Ratings and Markings

Use listed premises cables that have flammability ratings per NEC 770.50. Cables without markings should never be installed inside buildings, as they do not comply with the National Electrical Code. Optical cable markings are as follows:

OFN	optical fiber nonconductive
OFC	optical fiber conductive
OFNG or OFCG	general purpose
OFNP or OFCP	plenum rated cables for use in air-handling plenums
OFN-LS	low smoke density

5.3 Fiber Optic Cable Color Codes

5.3.1 Cable Jackets

Table 1 details color codes for premises fiber optic cables as specified in TIA-598.

Some indoor cables may be different colors than these, depending on the manufacturer or user.

Outdoor cables are generally black to prevent UV damage from the sun and the installer should rely on the identification printed on the cable jacket.

5.3.2 Fiber Color Codes

Fiber color codes are specified by TIA 598-A. In loose tube cables, this color code will be used for tubes as well as fibers within the tubes and sub-groups.

Fiber Type	Color Code		
	Commercial	Military	Printed Nomenclature
Multimode (50/125) OM2	Orange	Orange	50/125
Multimode (50/125) (850 nm Laser-optimized) OM3, OM4	Aqua	Undefined	850 LO 50/125
Multimode (62.5/125) (OM1)	Orange	Slate	62.5/125 OM1
Multimode (100/140)	Orange	Green	100/140
Singlemode (OS1, OS2)	Yellow	Yellow	SM/NZDS SM
Polarization Maintaining Singlemode	Blue	Undefined	Undefined

Table 1. Fiber optic cable color codes as specified in TIA-598.

Fiber No.	Color
1	Blue
2	Orange
3	Green
4	Brown
5	Slate
6	White
7	Red
8	Black
9	Yellow
10	Violet
11	Rose
12	Aqua

Connector color codes are covered in Section 6.2.1b

5.4 Installing Fiber Optic Cable

5.4.1 General

Fiber optic cable may be installed indoors or outdoors using several different installation processes. Outdoor cable may be direct buried, installed underground by being pulled or blown into conduit or innerduct, or installed aerially between poles. Indoor cables can be installed in raceways, cable trays, placed in hangers, pulled into conduit or innerduct or blown through special ducts with compressed gas. The installation process will depend on the nature of the installation and the type of cable being used.

Installation methods for both wire and optical fiber communications cables are similar. Fiber cable is designed to be pulled with much greater force than copper cable if pulled correctly, but excess stress may harm the fibers, potentially causing eventual failure.

5.4.2 Installation Guidelines

a) Follow the cable manufacturer's recommendations. Fiber optic cable is often custom designed for the installation and the manufacturer may have specific instructions on its installation.

b) Check the cable length to make sure the cable being pulled is long enough for the run to prevent having to splice fiber and provide special protection for the splices.

c) Try to complete the installation in one pull. Prior to any installation, assess the route carefully to determine the methods of installation and obstacles likely to be encountered.

D) Do not mix fiber optic cables and copper cables in one cable tray. Copper cables can be much heavier and damage the fiber cables by crushing. If needed, attach fiber ducts to the side of copper cable trays and pull the fiber into the duct.

5.4.2.1 Pulling Tension

- a) Cable manufacturers install special strength members, usually aramid yarn, for pulling. Fiber optic cable should only be pulled by these strength members. Any other method may put stress on the fibers and harm them.
- b) Swivel pulling eyes should be used to attach the pulling rope or tape to the cable to prevent cable twisting during the pull.
- c) Cables should not be pulled by the jacket unless it is specifically approved by the cable manufacturers and an approved cable grip is used.
- d) Tight buffer cable can be pulled over short distances by the jacket in premises applications if a large (~40 cm, 8 in.) spool is used as a pulling mandrel. Wrap the cable around the spool 5 times and hold gently when pulling.
- e) Do not exceed the maximum pulling tension rating. Consult the cable manufacturer and suppliers of conduit, innerduct, and cable lubricants for guidelines on tension ratings and lubricant use.
- f) On long runs pulled in conduit, it may be necessary to use lubricants. Make certain they are compatible with the cable jacket. If possible, use an automated puller with tension control and/or a breakaway pulling eye. On very long runs (farther than approximately 4 kilometers [2.5 miles]), pull from the middle out to both ends or use an automated fiber puller at

intermediate point(s) for a continuous pull.

- g) When laying loops of fiber on a surface during a pull, use “figure-8” loops to prevent twisting the cable (see Figure 3).

5.4.2.2 Bend Radius

Fiber optic cables are designed to withstand bending both during installation where tension is applied to the cable and after installation. There are general guidelines for most optical fiber cables using regular fiber. There are also fibers available that are rated as “bend-insensitive” that can withstand a smaller bend radius than regular fiber. Unless one knows that bend-insensitive fiber is used in a cable, use the following guidelines. For bend-insensitive fiber, follow the cable and/or fiber manufacturer’s recommendations.

- a) Do not exceed the cable bend radius. Fiber optic cable can be broken when kinked or bent too tightly, especially during pulling.

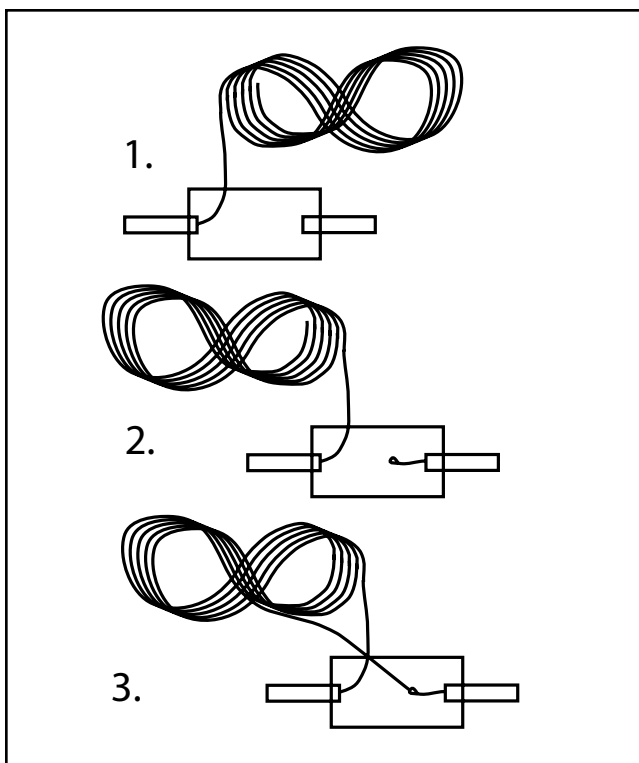

Figure 3. Use “figure 8” loops to protect the cable when pulling.

- b) If no specific recommendations are available from the cable manufacturer, the cable should not be pulled over a bend radius smaller than twenty (20) times the cable diameter.
- c) After completion of the pull, the cable should not have any bend radius smaller than ten (10) times the cable diameter.

5.4.2.3 Twisting Cable

- a) Do not twist the cable. Twisting the cable can stress the fibers. Tension on the cable and pulling ropes can cause twisting.
- b) Use a swivel pulling eye to connect the pull rope to the cable to prevent pulling tension causing twisting forces on the cable.
- c) Roll the cable off the spool instead of spinning it off the spool end to prevent putting a twist in the cable for every turn on the spool (see Figure 4).
- d) When laying cable out for a long pull, use a “figure 8” on the ground to prevent twisting. The figure 8 puts a half twist in on one side of the 8 and takes it out on the other, preventing twists.

5.4.2.4 Vertical Cable Runs

- a) It is preferable to drop vertical cables down rather than pulling them up whenever possible.
- b) Support cables at frequent intervals to prevent excess stress on the jacket. Support can be provided by cable ties (tightened snugly, not tightly enough to deform the cable jacket) or other suitable strain relief grip device.

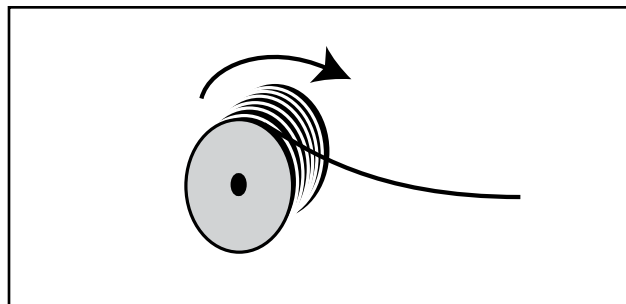

Figure 4. Roll cable off the spool to prevent twisting.

- c) Use service loops to assist in gripping the cable for support and to provide cable for future repairs or rerouting.

5.5 Cable Plant Hardware

All hardware and support structures should follow the recommendations of TIA-569 and NECA/BICSI 568.

5.5.1 Cable Racks, Trays, Conduit and Innerduct

- a) Outside plant cables can be installed in conduit or innerduct or direct-buried, depending on the cable type.
- b) Premises cabling can be installed in cable trays, ladder racks, J-hooks, or other approved support structures.

Note: The term approved is defined in other standards as acceptable to the authority having jurisdiction.

- c) Building cables can be installed directly, but installing them inside plenum-rated innerduct provides extra protection for the fiber cable. Innerduct is bright orange and will provide a good way to identify fiber optic cable and protect it from damage.

5.5.2 Fiber Optic Splicing and Termination Hardware

- a) *Breakout kits:* The fibers in loose tube cables have only the 250 micron primary buffer coating. Use breakout kits to separate and protect individual fibers in a loose tube cable for termination.
- b) *Splice enclosures:* For long cable runs outside, splices are necessary to connect lengths of cable. Splices require protection that is provided by a sealed splice enclosure. Choose enclosures that match the space required for the number of fibers in the cables and port locations and that matches the environment where it will be mounted. Splice enclosures can be sealed and buried in the ground, placed in a vault or suspended aurally.

- c) *Splice panels and patch panels:* Terminate or splice distribution cables inside panels or boxes to protect the fibers from damage. Boxes or panels may be rack-mounted or wall-mounted. All should have locks to prevent unauthorized entry.

- d) *Racks and cabinets:* Enclosures for patch panels and splice panels are used to terminate and organize cables. Use cable management hardware on the racks to route and separate cables to minimize potential for damage and facilitate moves, additions and changes.
- e) Take care with all splicing and termination hardware to maintain cable bend radiuses, prevent pinching or kinking of fibers and separate fibers to allow for future restoration, moves or other work.

5.6 Use of Cable Ties

Fiber optic cables, like all communications cables, are sensitive to compressive or crushing loads. Cable ties used with many cables, especially when tightened with an installation tool, are harmful to fiber optic cables, causing attenuation and potential fiber breakage.

- a) When used, cable ties should be hand tightened to be snug but loose enough to be moved along the cable by hand. Then the excess length of the tie should be cut off to prevent future tightening.
- b) Hook-and-loop fastener ties are preferred for fiber optic cables, as they cannot apply crush loads sufficient to harm the cable.

6. Fiber Optic Termination

6.1 General

Fiber optic termination processes vary according to the types of fiber being terminated. The style of connectors or splices used and the termination process shall match the connector. Fiber optic cable can be terminated in two ways, using:

- 1) Connectors that mate two fibers to create a temporary joint and/or connect the optical fiber to network equipment.
- 2) Splices which create a permanent joint between two fibers.

The decision whether to use connectors or splices depends on the application. All terminations must be of the right style, installed in a manner that provides low light loss and reflectance at the fiber joint, and is protected against the expected environment, dirt or damage while in use.

6.2 Fiber Optic Connectors

6.2.1 Choice of Connector

a) Choice of Connector Style

Fiber optic connectors are manufactured in a variety of different styles, (e.g. SC, ST, LC, MTP). While US industry standards allow the use of any connector with a reference TIA FOCIS document (Fiber Optic Connector Intermateability Standard), consideration should be given to compatibility with current cable plant hardware and system electronics.

Should the cable plant connectors be different from the electronics, hybrid patch cables will be required for connecting the cable plant to the electronics. In addition to color codes, incompatible connectors, e.g. SC and LC, can be used where one facility has two types of fibers such as 50/125 and 62.5/125

or multimode and singlemode to prevent mating incompatible fiber optic cables.

b) Connector Color Codes

The TIA-598 standard color code for connector bodies and/or boots is:

- 1) Beige for multimode connectors
- 2) Blue for single-mode connectors
- 3) Green for APC (angle physical contact) single-mode connectors

These color codes should be used in addition to the cable color codes or colored strain-relief boots on the connectors to also designate which type of optical fiber is in the cable being connected.

c) Choice of Termination Process

Fiber optic cable plants can be terminated in the field or prefabricated cable plants can be installed which require no field termination.

Fiber optic cables installed without connectors may be terminated by field termination by installing connectors onto the fibers using different types of termination processes or by splicing preterminated pigtailed onto each fiber.

Prefabricated cables or cable plants can be installed with terminations completed in a factory and shipped to the job site ready to install.

6.2.2 Field Termination Types

Several different types of terminations are available for optical fibers. Follow the manufacturer's directions exactly for the termination process used to ensure best connector performance and reliability.

a) Adhesive Terminations

Many connectors use epoxies or other adhesives to hold the fiber in the connector. Use only the specified epoxy, as the fiber-to-ferrule bond is critical for low loss and long term reliability.

- 1) *Epoxy/Polish*: The fiber is glued into the connector with two-part epoxy and the end polished with special polishing film. This method provides the most reliable connection and lowest losses. The epoxy can be allowed to set overnight or cured in a special oven. A “heat gun” should not be used to cure the epoxy as the uneven heat may not cure all the epoxy or may overheat it and prevent curing.
- 2) *Hot Melt*: This connector is similar to the epoxy/polish connector but already has the adhesive (heat set glue) inside the connector. The adhesive is liquefied in an oven before the fiber can be inserted. The fiber is secured when the adhesive cools.
- 3) *Anaerobic Adhesives*: These connectors use a quick-setting adhesive instead of the epoxy. They may use a single part adhesive or an adhesive and setting agent. Some adhesives do not have the wide temperature range of epoxies, so they should only be used indoors unless otherwise specified.

b) Crimp/Polish or Crimp/Cleave Terminations

These connectors use a crimp on the fiber to hold it in the connector ferrule. The fiber can be polished like an adhesive connector or cleaved with a special tool. Ensure the crimp is made as per the manufacturers’ specifications to prevent fiber pistoning (pulling back or pushing forward in the connector ferrule.)

c) Prepolished/Splice

These connectors have a short stub of fiber already epoxied into the ferrule and polished. Termination requires cleaving a fiber, inserting it into the back of the connector like a splice and crimping or fusion splicing in a special fixture. The loss of these connectors will generally be higher than adhesive connectors, since they include a connector loss plus a splice loss in every connector. To achieve low loss,

the fiber must be cleaved in a manner that utilizes good industry practices and techniques in addition to meeting applicable manufacturer’s requirements. Ensure the crimp is made as per the manufacturers’ specifications to prevent fiber pistoning (pulling back or pushing forward in the connector ferrule). The termination process can be monitored with a visual fault locator in many of these connectors.

6.2.3 Termination Process

- a) Whichever process is used for termination, follow the manufacturer’s instructions carefully.
- b) Use only adhesives approved by the manufacturer, and employ adhesive curing times in accordance with the manufacturer’s instructions.
- c) When special tools are required, they are to be used in accordance with manufacturers’ requirements.
- d) Once installation is completed, connectors should be covered with a fiber dust cap and stored in a safe location awaiting testing or connection to network equipment.

6.2.4 Connector Performance

Connector performance shall be within the limits of applicable industry standards. Loss and reflectance limits specified in industry standards is often higher than achieved routinely by experienced installers or specified by manufacturers. Users may specify a more stringent requirement and if so, that specification shall be used for acceptance.

6.2.5 Performance Verification

Following completed installation and termination, all terminated cables must be tested. Section 7 provides more detail on testing requirements at the conclusion of installation.

- a) Examine all connectors requiring polishing with a microscope for compliant end finish, cracks, scratches or dirt according to the International Electrotechnical Commission (IEC) standard IEC-61300-3-35.

- b) Test all fibers in all cables for loss using an OLTS (light source and power meter.) Test multimode cables using TIA-526-14, and singlemode cables using TIA-526-7. Total loss shall be less than the calculated maximum loss for the cable based on standards or customer specifications as calculated in a loss budget for the cable.

6.2.6 Fiber Polarization

In fiber networks, separate fibers are typically used for transmission in each direction, therefore it is necessary to identify the fiber connected to the transmitter and receiver at each end.

- a) Duplex connectors such as the duplex SC are polarized, that is they are keyed to allow connection in only one orientation. Follow the polarization rules given in TIA-568, Section 5.2.4.
- b) Simplex connectors should be documented for connections and when allocated to the transceiver of networking equipment, marked for transmit and receive at each end of the link.

6.3 Fiber Optic Splices

6.3.1 Types of Splices

Splices are a permanent joint or connection between two fibers. There are two basic types of splices, fusion and mechanical.

- a) *Fusion Splices:* These “weld” the two fibers together with heat, usually in an electric arc. Fusion splicers are generally automated and produce splices that have minimal losses. Fusion splicing should not be performed in a dusty or explosive atmosphere as the electric arc may cause an explosion or fire.
- b) *Mechanical Splices:* These align two fibers in a ferrule or v-groove with index-matching gel or adhesive between the fibers to reduce loss and back reflection. Mechanical splices are used for temporary restoration as well as permanent joints.

6.3.2 Splice Performance

Splice performance shall be within industry standard limits as specified in TIA-568. Splice performance may be specified by end users at a different value, and if so, those values shall be used for acceptance.

6.3.3 Splice Performance Verification

End-to-end tests of fiber optic cable loss include the losses caused by splices. If the cable loss exceeds the calculated maximum value, or if the customer requires splice loss verification, test the cable with an OTDR to analyze the loss of individual components (fiber, connectors, and splices) in the cable. Test splice loss in both directions and average the measured values to reduce the directional effects of OTDR measurements.

6.3.4 Splice Protection

Splices shall be placed in a protective enclosure that matches the environment. Cables shall be secured at the entry to the closure. Typical closures for loose tube cable will have fiber tubes leading to a splice tray where individual fibers are spliced and carefully placed to prevent damage when the splice tray is closed and placed in the closure. Splice enclosure specifications shall match the requirements of all fiber, tube and cable lengths to prevent damage to the cable and fibers.

7. Testing the Installed Fiber Optic Cable Plant

7.1 General

After installation, test each fiber in all fiber optic cables for verification of installation performance and in conformance with applicable standards. Perform the following tests:

- a) Continuity testing to determine that the fiber routing and/or polarization is correct and documentation is proper.
- b) End-to-end insertion loss using an OLTS power meter and source. Test multimode cables by using TIA-526-14, and singlemode cables using TIA-526-7. Total loss shall be less than the calculated maximum loss for the cable based on appropriate standards or customer specifications as calculated in the loss budget.
- c) Optional OTDR testing may be used to verify cable installation, splice performance and troubleshoot problems.
- d) If the design documentation does not include cable plant length, and this is not recorded during installation, test the length of the fiber using the length feature available on an OTDR or some OLTSs.
- e) If testing shows variances from expected losses troubleshoot the problems and correct them.

7.2 Continuity Testing

Perform continuity testing of optical fibers using a visual fiber tracer, visual fault locator, or OLTS power meter and source. Trace the fiber from end to end through any interconnections to insure that the path is installed in accordance with the requirements in applicable standards, and that polarization and routing are correct and documented.

7.3 Insertion Loss

Insertion loss refers to the optical loss of the installed fibers when measured with a test source and power meter (OLTS). Test multimode cables by using TIA 526-14, and singlemode cables using TIA 526-7. *See Appendix B.*

- a) Test multimode fiber at 850 and 1300 nm, and singlemode fiber at 1310 and 1550 nm, unless otherwise required by other standards or customer requirements.
- b) Test reference test cables to verify quality and clean them often.
- c) Cabling intended for use with high-speed systems using laser sources may be tested with laser sources to ensure that tests verify performance with that type of source.
- d) Some testing standards require the use of a mode conditioner to modify the mode power distribution in fibers when testing multimode cables. Follow the directions for its use to gain the proper test results.

7.4 OTDR Testing

The optical time domain reflectometer (OTDR) uses optical radar-like techniques to create a picture of a fiber in an installed fiber optic cable. The picture, called a signature or trace, contains data on the length of the fiber, loss in fiber segments, connectors, splices and loss caused by stress during installation.

OTDRs are used to verify the quality of the installation or for troubleshooting. However, OTDR testing is an indirect test that may not be comparable to transmission system loss and should not be used to determine cable loss.

OTDR testing should only be performed by trained personnel using certified equipment designed for the purpose. The technicians performing the tests should be trained not only in operation of the OTDR equipment, but also in the interpretation of OTDR traces.

See Annex B for more information on OTDR testing.

8. Administration, Management, and Documentation

8.1 General

Documentation of the fiber optic cable plant is an integral part of the design, installation and maintenance process for the fiber optic network. Documenting the installation effectively will facilitate installation, allow better planning for upgrading, and simplify testing for future moves, additions and changes.

Documentation of the fiber optic cable plant should follow TIA-606, *Administration Standard for the Telecommunications Infrastructure of Commercial Buildings* or specific customer requirements.

Fiber optic cables, especially those used for backbone cables, may contain many fibers that connect a number of different links going to several different locations with interconnections at patch panels or splice closures. The fiber optic cable plant should be documented as to the exact path that every fiber in each cable follows, including intermediate connections and every connector type.

Documentation should also include insertion loss data and optional OTDR traces.

(This annex is not a part of the standard)

Annex A: Calculating the Loss Budget for a Fiber Optic Cable Plant

Calculating the loss budget for a fiber optic link should be done as part of the initial design of the link. A loss budget will estimate the loss of the link to provide assurance that the link will support telecommunications equipment intended for use on the link. It should also be used to provide an estimated loss value to use when testing the link with a test source and power meter after installation to determine if the link has been installed correctly.

A.1 Information Necessary to Calculate Loss Budget

The following information is needed to calculate a loss budget:

- length of the link, end to end, in meters,
- number of connections, including connectors on each end
- number of splices.

In the table below, attenuation coefficients are given from TIA-568, which is considered the worst-case, and for typical industry results. The table below shows typical loss for each component in an installed link.

Fiber Attenuation Coefficient

Fiber Type	Wavelength (nm)	Max Attenuation Coefficient Per TIA-568 (dB/km)	Attenuation Coefficient (typical)(dB/km)
50/125	850	3.5	3
	1300	1.5	1
62.5/125	850	3.5	3
	1300	1.5	1
Singlemode (Premises)	1310	1.0	0.5
	1550	1.0	0.5
Singlemode (Outside Plant)	1310	0.5	0.4
	1550	0.5	0.3

Loss of Connections and Splices

	Max Loss Per TIA-568 (dB)	Typical Loss(dB)
Connection (2 mated connectors)	0.75	0.3 (Adhesive/polish type) 0.5-0.75 (prepolished/splice type), 0.75 (single ferrule multifiber array)
Splice (fusion or mechanical)	0.3	0.05 (fusion) 0.3 (mechanical)

A.2 Process:

1. Calculate the loss of the fiber
2. Calculate the loss of all connections
3. Calculate the loss of all splices
4. Add all losses to get the total loss

A.3 Calculate the fiber loss:

Multiply the length of the fiber times the attenuation coefficient of the fiber at each wavelength of interest. Multimode fiber is calculated for 850 nm and 1300 nm. Singlemode fiber is generally calculated for 1310 nm for most premises applications and 1310 nm and 1550 nm for outside plant applications.

For example, multimode fiber at 850 nm:

Estimated fiber loss = length in km X 3.5 dB/km (TIA Max Specification)

or

Estimated fiber loss = length in km X 3 dB/km (Typical Specification)

A.4 Calculate the connector loss:

The loss of a connection is the loss of a joint created by mating a pair of connectors. Estimates should always include the loss of the two connectors on the end of the cable plant since they will be mated to reference cables when being tested. Count the number of connections and multiply by the estimated loss of each connection.

For example, a cable plant with 3 connections plus the end connectors:

Total connection loss = Number of connections (5) X 0.75 dB (TIA Max Specification) = 3.75 dB

or

Total connection loss = Number of connections (5) X 0.3 dB (Typical Specification) = 1.5 dB

A.5 Calculate the splice loss:

If the cable plant has splices, count the number of splices and multiply by the estimated loss of each splice.

For example, a cable plant with 3 fusion splices:

$$\text{Total splice loss} = \text{Number of splices (3)} \times 0.3 \text{ dB (TIA Max Specification)} = 0.9 \text{ dB}$$

or

$$\text{Total splice loss} = \text{Number of splices (3)} \times 0.05 \text{ dB (Typical Specification)} = 0.15 \text{ dB}$$

A.6 To calculate the total cable loss, add the losses calculated above:

$$\text{Total fiber loss in dB} = (\text{fiber loss}) + (\text{connector loss}) + (\text{splice loss})$$

A.7 Interpreting the result:

Use these numbers as estimates for “pass/fail” limits for testing. If the field-measured loss is significantly higher than the calculated value, troubleshoot the installation.

(This annex is not a part of the standard)

Annex B: Field Test Requirements

B.1 General

Installed fiber optic cable plant performance depends on component quality and specifications, length of the fiber in the cables, number of connections and/or splices and the quality of the installation process itself. Testing each fiber in the cables verifies the quality of the components and the installation process. All fibers should be tested for insertion loss with a test source and power meter (also called an optical loss test set) and the test results compared to the loss estimated in the calculated loss budget. OTDR tests may be used for troubleshooting. All test data should be recorded and records maintained for reference in case of future problems or the need for restoration of failed links.

B.2 Insertion Loss Of Fiber Optic Cables

All optical fiber cables and cable plants shall be tested for insertion loss. Insertion loss refers to the optical loss of the installed fibers when measured with a test light source and power meter (OLTS) which simulates cable plant usage.

There are many standards that cover testing of the installed cable plant. All of which include the procedures shown here. To test premises cabling installed according to TIA-568, use TIA-526-14 for multimode cable, or TIA-526-7 Method A.1 for singlemode cable. Both methods recommend a single reference launch cable calibration as shown in B.2.1. Some types of fiber optic connectors require two- or three-cable referencing, which is allowed as long as the method is documented.

Cables may be tested per other methods as required by the user.

B.2.1 Test Procedure

Insertion loss is tested by connecting a test source through a mating reference cable (launch reference cable) to the cable plant under test and measuring the loss with a power meter attached to the cable plant with another cable (receive reference cable) using the following procedure.

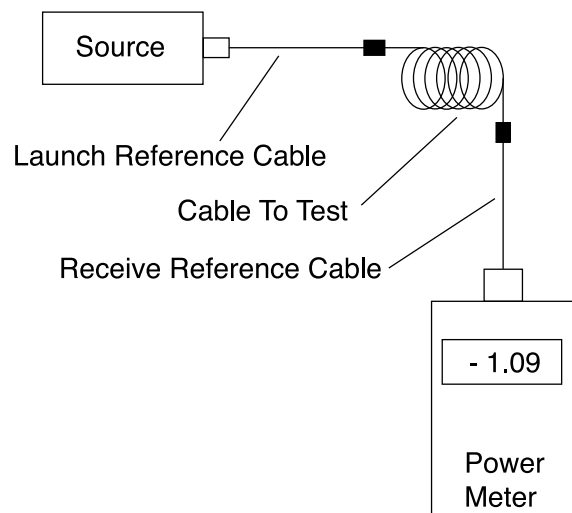

B.2.1.1 Setting The "0 dB" Reference

Standards allow setting a "0 dB" reference value for measuring loss in three different ways, which should be used either as required by the standard or as necessary due to cable plant and test instrument compatibility. The method used shall be included in the documentation since the measured loss varies with each method.

- a) *1-Cable Reference:* Many standards call for using a one cable reference which measures the output of the launch reference cable with a power meter and

sets this as the “0 dB” reference. This method is preferred and will work when the cable plant connectors are compatible with the test equipment or can be adapted using hybrid mating adapters, e.g. ST to SC mating.

b) *2-Cable Reference:* If the cable plant connectors are not compatible with the test instruments, e.g. LC connectors on the cable plant and SC connectors on the instruments, a two cable reference method (TIA-526-14, Method A) can be used. Use hybrid reference cables with SC connectors to mate with the instruments and LC connectors on the other end to mate with the cable plant. Attach the SC connector ends of the reference cables to the instruments then mate the LC ends with a mating adapter to set the “0 dB” reference. When making the measurements of loss, the value measured will be lower by the loss of the connection between the reference cables included in setting the reference.

c) *3-Cable Reference:* If the cable plant connectors are “plug and jack” type and not compatible with the test instruments, e.g. MTRJ or MTP connectors on the cable plant and SC connectors on the instruments, a three-cable reference method (TIA-526-14, Method C) must be used. In this method, the reference cables attached to the test source and power meter are mated to a third reference cable, a short version of the cable plant to be tested, for setting the “0 dB” reference. When making the measurements of loss, the value measured will be lower by the loss of the two connections included between the reference cables in setting the reference. must be used. In this method, the reference cables attached to the test source and power meter are mated to a third reference cable, a short version of the cable plant to be tested for setting the “0 dB” reference. When making the measurements of loss, the value measured will be lower by the loss of the two connections included in setting the reference.

B.2.1.2 Making Insertion Loss Measurements

1. To measure the loss after the 0 dB reference has been set, the light source is coupled to one end of the cable under test with a launch reference cable and the optical power meter is coupled

to the cable under test using a reference cable (receive cable.)

2. The light from the test source is attenuated by the cable under test, beginning at the connection to the launch cable, while passing through all fiber in the cable, connectors and splices, and finally the connection to the receive cable.
3. The loss of the cable is the difference of the 0 dB reference set and the output of the cable being tested as measured by the power meter, expressed in dB.

Notes:

1. Test multimode fiber at 850 and 1300 nm and singlemode fiber at 1310 and 1550 nm or as required by other standards or customer requirements.
2. Clean reference cables between every measurement and test reference cables frequently to verify quality.

B.2.2 Test Instruments

a) *Test source:* The test source shall be of a source and wavelength suitable for the cabling system being tested.

1. Use LED sources to test multimode fiber at 850 and 1300 nm and laser sources to test singlemode fiber at 1310 and 1550 nm.
2. Multimode test sources should meet applicable standards for mode power distribution and be used with correctly sized mandrel wrap mode filters or other mode conditioners when specified by the standard.

b) *Optical power meter:* The optical power meter shall be suitable for the cabling system being tested.

1. The optical power meter shall be calibrated at the wavelengths suitable for the test source.
2. The optical power meter shall have a measurement range suitable for the loss ranges being tested.

3. Adapters for connector types being tested shall be available.
4. The optical power meter shall be calibrated by a calibration laboratory and in accordance with the manufacturer's recommended recalibration interval(s).

c) *Reference test cables*: Reference test cables shall be compatible with the cable plant being tested.

1. Cables shall match the type (multimode or singlemode) of fiber being tested and, if multimode, the core size (50 or 62.5 micron). Bend-insensitive fibers may not be appropriate as reference cables for testing all types of fibers. Consult the cable manufacturer for recommendations.
2. Cables shall be of good quality and tested to verify low loss. Unless otherwise specified, losses of reference cables should not exceed 0.5 dB when tested single-ended according to TIA-455-171.
3. Once attached to the test source and the "0 loss" reference measurement made, the launch reference cable should not be removed from the source as it may invalidate the reference.
4. Cables should be cleaned before each measurement, inspected with a microscope and tested periodically to verify quality.

B.2.3 Insertion Loss Measurement Uncertainty

Insertion loss testing has several sources of measurement uncertainty that should be understood by personnel making the test.

1. Insertion loss measurements depend on the quality and condition of the launch and receive reference cables since the connectors on these cables mates to the connectors on the cable under test. Poor quality, wear, scratches or dirt on these connectors will cause the measurement of loss to be higher and may not represent the actual quality of the cable being tested. Cables used as reference cables should be cleaned, inspected and tested regularly.

2. Optical sources will affect loss measurements in several ways. Fiber attenuation varies with wavelength, so the wavelength of the source will affect the loss of long cables. LED sources used for multimode testing will affect the loss of both the fiber and any joints in the fiber according to how the source launches light into the modes of the fiber. Standards describe several ways to condition the modal distribution that may be relevant to the cable being tested.
3. Setting the "0 dB reference" using the two or three cable reference method may cause increased uncertainty in the loss value, even showing a "gain" if the reference was set improperly or the connections on the reference cables were dirty.

B.3 OTDR Testing

Testing with an optical time domain reflectometer (OTDR) may be performed to verify the quality of the installation, or for troubleshooting. However, it shall not be used as a measurement of the loss of the cable plant.

B.3.1 Test Procedure

OTDR testing uses backscattered light from the optical fiber to create a diagram, called a "trace" or "signature," of the cable plant being tested. The OTDR needs access to only one end of the optical fiber to perform testing, but reference cables are needed at both ends of the cable plant to allow testing connectors on each end of the cable.

1. Attach the OTDR to the fiber in the cable plant to be tested through a launch cable of a fiber type and size that matches the cable under test. The launch cable, also called a "pulse suppressor cable," must be long enough to allow the OTDR to overcome the overload caused by the test pulse. The launch cable will also provide a mating connector to the cable under test. A similar cable shall be used on the far end of the cable (sometimes called a receive cable or tail cord) under test to provide a reference connection for testing the loss of the end connector.

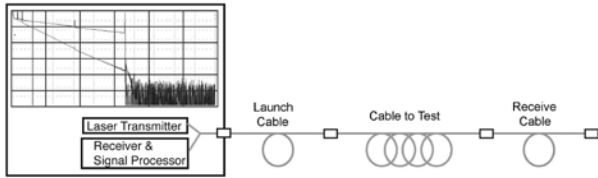

2. Adjust the OTDR settings (range, wavelength, averaging, etc.) for the cable under test.
3. Obtain a trace of the fiber being tested.
4. Analyze the OTDR trace for fiber length and events (connectors, splices, locations of stress losses.)
5. Test in each direction and average to obtain absolute loss values of splices and connectors.

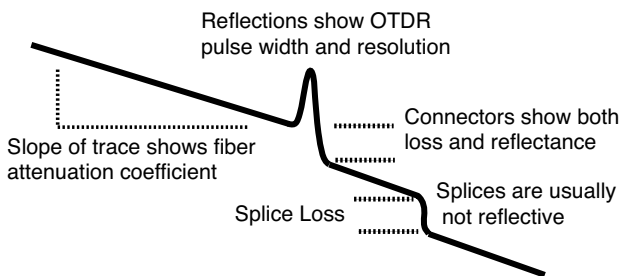

6. Store a copy of the trace for submission with other test data and cable plant documentation.

B.3.2 OTDR Measurement Uncertainty

OTDR measurements should follow procedures outlined by the OTDR vendors. OTDR measurements may have errors associated with the nature of the measurement, the setup of test parameters or the interpretation of the traces. It is recommended that OTDRs only be used by trained personnel who know how to set up the instrument and interpret the results. It is recommended that users not use any automatic testing option until several fibers have been tested and interpreted by a knowledgeable operator to ensure the data matches the installed fiber parameters.

1. OTDRs use an indirect method of measurement that depends on the backscatter coefficient of the fiber and may not correlate with direct insertion loss testing.
2. Joints between dissimilar fibers (splices or connections) with different backscatter coefficients will show different losses when tested in both directions, even showing a gain in one direction. Average the readings to get a loss that has less uncertainty.
3. OTDRs have a distance resolution limited by the width of the test pulse. Set the pulse as short as possible for the range needed to reach the end of the cable plant being tested for best resolution.
4. OTDRs are generally not useful for short cables. If the trace does not show a flat trace of fiber loss after a connection, the cable is too short to test.
5. High reflectance events may cause spurious events called “ghosts.” Ghosts look like connectors but have no loss.

The FOA Online Reference Guide has an extensive tutorial on using OTDRs.

(This annex is not a part of the standard)

Annex C: Reference Standards

This publication, when used in conjunction with the National Electrical Code, National Electrical Safety Code, and cable manufacturers' literature, provides sufficient information to install and test fiber optic cables.

Standards are under continuous development therefore it is recommended that the user obtain the latest versions of all referenced standards.

National Fire Protection Association
1 Batterymarch Park
P.O. Box 9101
Quincy, MA 02269-9101
(617) 770-3000 tel
(617) 770-3500 fax
www.nfpa.org

NFPA 70-2017, *National Electrical Code (ANSI)*

Institute of Electrical and Electronics Engineers
445 Hoes Lane
P.O. Box 1331
Piscataway, NJ 08855-1331
(732) 981-0060 tel
(732) 981-9667 fax
www.ieee.org

IEEE 1100, *IEEE Recommended Practice for Powering and Grounding Electronic Equipment ANSI*

C2-2017, *National Electrical Safety Code*

Telecommunications Industry Association
2500 Wilson Blvd.
Arlington, VA 22201
(703) 907-7700 tel
(703) 907-7727 fax
www.tiaonline.org

ANSI/TIA-568, *Commercial Building Telecommunications Cabling Standard*

ANSI/TIA-569, *Commercial Building Standard for Telecommunications Wiring Pathways and Spaces*

ANSI/TIA-606-A, *Administration Standard for Commercial Telecommunications Infrastructure*

ANSI/TIA-607, *Commercial Building Grounding and Bonding Requirements for Telecommunications*

TIA-455-57, *Optical Fiber End Preparation and Examination*

TIA-526-14, *Optical Power Loss Measurements Of Installed Multimode Fiber Cable Plant*

TIA-526-7, *Optical Power Loss Measurements Of Installed Singlemode Fiber Cable Plant*

Current National Electrical Installation Standards published by NECA:

National Electrical Contractors Association
3 Bethesda Metro Center, Suite 1100
Bethesda, MD 20814
(301) 215-4504 tel
(301) 215-4500 fax
www.neca-neis.org

NECA 1-2015, *Standard for Good Workmanship in Electrical Construction* (ANSI)

NECA 90-2015, *Standard for Commissioning Building Electrical Systems* (ANSI)

NECA 100-2013, *Symbols for Electrical Construction Drawings* (ANSI)

NECA 101-2013, *Standard for Installing Steel Conduits (Rigid, IMC, EMT)* (ANSI)

NECA 102-2004, *Standard for Installing Aluminum Rigid Metal Conduit* (ANSI)

NECA/AA 104-2012, *Standard for Installing Aluminum Building Wire and Cable* (ANSI)

NECA/NEMA 105-2015, *Standard for Installing Metal Cable Tray Systems* (ANSI)

NECA 111-2003, *Standard for Installing Nonmetallic Raceways (RNC, ENT, LFNC)* (ANSI)

NECA/NACMA 120-2012, *Standard for Installing Armored Cable (AC) and Metal-Clad Cable (MC)* (ANSI)

NECA 121-2007, *Standard for Installing Nonmetallic-Sheathed Cable (Type NM-B) and Underground Feeder and Branch-Circuit Cable (Type UF)* (ANSI)

NECA 130-2016, *Standard for Installing and Maintaining Wiring Devices* (ANSI)

NECA 169-2016, *Standard for Installing and Maintaining Arc-Fault Circuit Interrupters (AFCIs) and Ground-Fault Circuit Interrupters (GFCIs)* (ANSI)

NECA 200-2016, *Standard for Installing and Maintaining Temporary Electric Power at Construction Sites* (ANSI)

NECA 202-2013, *Standard for Installing and Maintaining Industrial Heat Tracing Systems* (ANSI)

NECA 230-2016, *Standard for Selecting, Installing, and Maintaining Electric Motors and Motor Controllers* (ANSI)

NECA/FOA 301-2016, *Standard for Installing and Testing Fiber Optic Cables* (ANSI)

NECA 303-2005, *Standard for Installing Closed-Circuit Television (CCTV) Systems* (ANSI)

NECA 305-2010, *Standard for Fire Alarm System Job Practices* (ANSI)

NECA 331-2009, *Standard for Building and Service Entrance Grounding and Bonding*

NECA 400-2007, *Standard for Installing and Maintaining Switchboards* (ANSI)

NECA 402-2014, *Standard for Installing and Maintaining Motor Control Centers* (ANSI)

NECA/EGSA 404-2014, *Standard for Installing Generator Sets* (ANSI)

NECA 406-2014, *Standard for Installing Residential Generator Sets* (ANSI)

NECA 407-2015, *Standard for Installing and Maintaining Panelboards* (ANSI)

NECA 408-2015, *Standard for Installing and Maintaining Busways* (ANSI)

NECA 409-2015, *Standard for Installing and Maintaining Dry-Type Transformers* (ANSI)

NECA 410-2013, *Standard for Installing and Maintaining Liquid-Filled Transformers* (ANSI)

NECA 411-2014, *Standard for Installing and Maintaining Uninterruptible Power Supplies (UPS)* (ANSI)

NECA 412-2012, *Standard for Installing and Maintaining Photovoltaic (PV) Power Systems* (ANSI)

NECA 413-2012, *Standard for Installing and Maintaining Electric Vehicle Supply Equipment* (ANSI)

NECA 420-2014, *Standard for Fuse Applications* (ANSI)

NECA 430-2016, *Standard for Installing Medium-Voltage Switchgear* (ANSI)

NECA/IESNA 500-2006, *Standard for Installing Indoor Commercial Lighting Systems* (ANSI)

NECA/IESNA 501-2006, *Standard for Installing Exterior Lighting Systems* (ANSI)

NECA/IESNA 502-2006, *Standard for Installing Industrial Lighting Systems* (ANSI)

NECA 503-2005, *Standard for Installing Fiber Optic Lighting Systems*

NECA/BICSI 568-2006, *Standard for Installing Commercial Building Telecommunications Cabling* (ANSI)

NECA/NCSCB 600-2014, *Standard for Installing and Maintaining Medium-Voltage Cable* (ANSI)

NECA/NEMA 605-2005, *Recommended Practice for Installing Underground Nonmetallic Utility Duct*

NECA/BICSI 607-2011, *Standard for Telecommunications Bonding and Grounding Planning and Installation Methods for Commercial Buildings* (ANSI)

NECA 700-2016, *Standard for Installing Overcurrent Protection to Achieve Selective Coordination* (ANSI)

NECA 701-2013, *Standard for Energy Management, Demand Response and Energy Solutions* (ANSI)

<This page intentionally left blank>

<This page intentionally left blank>

<This page intentionally left blank>



National Electrical Contractors Association

3 Bethesda Metro Center, Suite 1100
Bethesda, Maryland 20785
301-657-3110 • 301-214-4500 fax
www.necanet.org